



DE	Blutdruckmessgerät Gebrauchsanweisung	2
EN	Blood pressure monitor Instructions for use	16
FR	Tensiomètre Mode d'emploi	29
ES	Tensiómetro Manual de instrucciones	43
IT	Misuratore di pressione Istruzioni per l'uso	57
TR	Tansiyon ölçme cihazı Kullanım kılavuzu	71
RU	Прибор для измерения кровяного давления в Инструкция по применению	84
PL	Ciśnieniomierz Instrukcja obsługi	98

Content

1. Getting to know your instrument	16
2. Important information	17
3. Unit description	20
4. Prepare measurement	21
5. Measuring blood pressure.....	22
6. Evaluating results	24
7. Saving, displaying and deleting measured values	25
8. Cleaning and storing the device and cuff.....	26
9. Error messages/troubleshooting.....	26
10. Specifications.....	26
11. Mains part.....	27
12. Replacement parts and wearing parts	28
13. Warranty/service	28

Included in delivery

- Blood pressure monitor
- Upper arm cuff
- 4 x 1.5 V LR6 AA batteries
- Storage bag
- Instructions for use

Dear Customer,

Thank you for choosing one of our products. Our name stands for high-quality, thoroughly tested products for applications in the areas of heat, weight, blood pressure, body temperature, pulse, gentle therapy, massage, beauty and air.

Please read these instructions for use carefully and keep them for later use, be sure to make them accessible to other users and observe the information they contain.

Best regards,
Your Beurer Team

1. Getting to know your instrument

Check that the device packaging has not been tampered with and make sure that all contents are present. Before use, ensure that there is no visible damage to the device or accessories and that all packaging material has been removed. If you have any doubts, do not use the device and contact your retailer or the specified Customer Services address.









The upper arm blood pressure monitor is used for non-invasive measurement and monitoring of adults' arterial blood pressure. You can use it to measure your blood pressure quickly and easily, storing the results and displaying the progression of readings together with the average.







A warning is issued for anyone suffering from cardiac arrhythmia. The recorded values are classified and evaluated graphically. Store these instructions for use for future reference and make them accessible to other users.

2. Important information

Signs and symbols

The following symbols are used in these instructions for use, on the packaging and on the type plate for the device and accessories:

	Attention
	Note Note on important information
	Observe the instructions for use
	Application part, type BF
	Direct current
	Disposal in accordance with the Waste Electrical and Electronic Equipment EC Directive – WEEE
	Dispose of packaging in an environmentally friendly manner
	Manufacturer

	Permissible storage and transport temperature and humidity
	Permissible operating temperature and humidity.
	Protect from moisture
	Serial number
	The CE labelling certifies that the product complies with the essential requirements of Directive 93/42/EEC on medical products.
	Certification symbol for products that are exported to the Russian Federation and CIS countries.

Advice on use

- In order to ensure comparable values, always measure your blood pressure at the same time of day.
- Before every measurement, relax for about five minutes.
- If you want to perform several measurements on the same person, wait five minutes between each measurement.
- Do not take a measurement within 30 minutes after eating, drinking, smoking or exercising.
- Repeat the measurement if you are unsure of the measured value.



- The measurements taken by you are for your information only – they are not a substitute for a medical examination! Discuss the measurements with your doctor, and never base any medical decisions on them (e.g. medicines and their administration)!
- Using the blood pressure monitor outside your home environment or whilst on the move (e.g. whilst travelling in a car, ambulance or helicopter, or whilst undertaking physical activity such as playing sport) can influence the measurement accuracy and cause incorrect measurements.
- Do not use the blood pressure monitor on newborns or patients with preeclampsia. We recommend consulting a doctor before using the blood pressure monitor during pregnancy.
- Cardiovascular diseases may lead to incorrect measurements or have a detrimental effect on measurement accuracy. The same also applies to very low blood pressure, diabetes, circulatory disorders and arrhythmias as well as chills or shaking.
- The blood pressure monitor must not be used in connection with a high-frequency surgical unit.
- Only use the device on people who have the specified upper arm measurement for the device.
- Please note that when inflating, the functions of the limb in question may be impaired.
- During the blood pressure measurement, blood circulation must not be stopped for an unnecessarily long time. If the device malfunctions, remove the cuff from the arm.
- Avoid any mechanical restriction, compression or bending of the cuff line.
- Do not allow sustained pressure in the cuff or frequent measurements. The resulting restriction of the blood flow may cause injury.
- Ensure that the cuff is not placed on an arm in which the arteries or veins are undergoing medical treatment, e.g. intra-vascular access or therapy, or an arteriovenous (AV) shunt.
- Do not use the cuff on people who have undergone a mastectomy.
- Do not place the cuff over wounds as this may cause further injury.
- You can either use the blood pressure monitor with batteries or with a mains part. Please note that data transfer and data storage is only possible when your blood pressure monitor is supplied with power. As soon as the batteries are empty or the mains part is disconnected from the power supply, the blood pressure monitor loses the date and time.
- To conserve the batteries, the monitor switches off automatically if no buttons are pressed for 3 minutes.
- The device is only intended for the purpose described in these instructions for use. The manufacturer is not liable for damage resulting from improper or careless use.

Storage and Care

- The blood pressure monitor is made up of precision electronic components. Accuracy of readings and the instrument's service life depend on careful handling.
 - You should protect the device from impact, moisture, dirt, major temperature fluctuations and direct exposure to the sun's rays.
 - Never drop the device.

- Do not use near strong electromagnetic fields, i.e. keep it away from any radio systems and mobile phones.
- Only ever use the cuffs provided with the monitor or original replacement cuffs. Otherwise erroneous results will be recorded.
- If the instrument is not used for any length of time, we recommend removing the batteries.

Notes on handling batteries

- If your skin or eyes come into contact with battery fluid, flush out the affected areas with water and seek medical assistance.
-  **Choking hazard!** Small children may swallow and choke on batteries. Store the batteries out of the reach of small children.
- Observe the plus (+) and minus (-) polarity signs.
- If a battery has leaked, put on protective gloves and clean the battery compartment with a dry cloth.
- Protect the batteries from excessive heat.
-  **Risk of explosion!** Never throw batteries into a fire.
- Do not charge or short-circuit batteries.
- If the device is not to be used for a long period, take the batteries out of the battery compartment.
- Use identical or equivalent battery types only.
- Always replace all batteries at the same time.
- Do not use rechargeable batteries.
- Do not disassemble, split or crush the batteries.

Repair and disposal

- Batteries do not belong in domestic refuse. Used batteries should be disposed of at the collection points provided.
- Never open the instrument. If these instructions are not heeded, the warranty will be null and void.
- Never attempt to repair the instrument or adjust it yourself. We can no longer guarantee perfect functioning if you do.
- Repairs may only be performed by Customer Service or authorized dealers. However, always check the batteries and replace them if necessary prior to making any complaint.
- For environmental reasons, do not dispose of the device in the household waste at the end of its useful life. Dispose of the unit at a suitable local collection or recycling point. Dispose of the device in accordance with EC Directive – WEEE (Waste Electrical and Electronic Equipment). If you have any questions, please contact the local authorities responsible for waste disposal.



Notes on electromagnetic compatibility

- The device is suitable for use in all environments listed in these instructions for use, including domestic environments.
- The use of the device may be limited in the presence of electromagnetic disturbances. This could result in issues such as error messages or the failure of the display/device.
- Avoid using this device directly next to other devices or stacked on top of other devices, as this could lead to faulty operation. If, however, it is necessary to use the device in the manner stated, this device as well as the other devices must be monitored to ensure they are working properly.

- The use of accessories other than those specified or provided by the manufacturer of this device can lead to an increase in electromagnetic emissions or a decrease in the device's electromagnetic immunity; this can result in faulty operation.
- Failure to comply with the above can impair the performance of the device.

3. Unit description

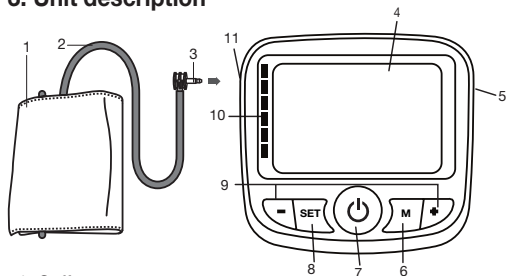

1. Cuff
2. Cuff tube
3. Cuff connector
4. Display
5. Connection for mains part
6. Memory button **M**
7. START/STOP button
8. **SET** button
9. Function buttons **-/+**
10. Risk indicator
11. Connection for cuff connector (left-hand side)

Icons in the display:

1. Date
2. Time
3. Inflate , release air
4. Systolic pressure
5. Memory display, average value **AVG**
6. Unit in mmHg
7. Diastolic pressure
8. Battery replacement symbol
9. Pulse symbol
10. Memory space number **NO**
11. Cardiac arrhythmia symbol
12. Calculated pulse value / memory space number / memory display, average value (RL), morning (R), evening (P)
13. User memory
14. Risk indicator

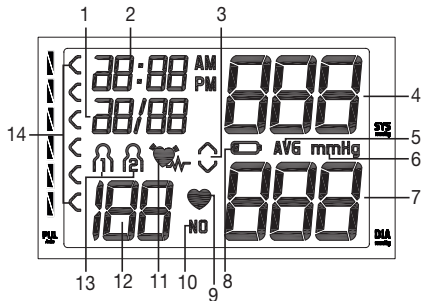

4. Prepare measurement

Inserting battery

- Remove the battery cover from the back of the monitor.
- Insert four AA 1.5V alkaline batteries. Making absolutely sure that you insert them with the correct polarity as marked.
Never use rechargeable batteries.
- Replace the battery cover carefully.

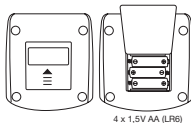

If 4 warning tones have been sounded and the symbol  appears simultaneously on the display, it is no longer possible to perform a measurement and all batteries must be replaced. Once the batteries have been removed from the device, the date and time must be set again. Any saved measurements are retained.

Battery disposal

- The empty, completely flat batteries must be disposed of through specially designated collection boxes, recycling points or electronics retailers. You are legally required to dispose of the batteries.
- The codes below are printed on batteries containing harmful substances:
Pb = Battery contains lead,
Cd = Battery contains cadmium,
Hg = Battery contains mercury

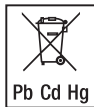

Setting the user memory, date and time

This menu allows you to set the following functions, one after another.

User memory → Date → Time

It is essential to set the date and time. Otherwise, you will not be able to save your measured values correctly with a date and time to retrieve them later.

The time is displayed in the 24-hour format.

 If you press and hold the function buttons **-/+**, you can set the values more quickly.

- Press the **SET** button.

The user memory symbol flashes on the display.

- Select the desired user memory by pressing the function buttons **-/+**.



You have two memories, each with 60 memory spaces, to store the measurements of two different people separately.

- Confirm using the **SET** button.

User memory

The year flashes on the display.

- Set the year with the function buttons **-/+** and confirm with the **SET** button.
- Set the month, day, hour and minute and confirm each setting with the **SET** button.

When making settings, you can use the **START/STOP** button **⏻** at any time to switch the device off. The settings that have already been performed will be retained.

Operation with the mains part

You can also operate this device with a mains part. When doing so, there must not be any batteries in the battery compartment. The mains part can be obtained from specialist retailers or from the service address using order number 071.95.

- To prevent possible damage to the device, the blood pressure monitor must only be used with the mains part described here.
- Insert the mains part into the connection provided for this purpose on the right-hand side of the blood pressure monitor. The mains part must only be connected to the mains voltage that is specified on the type plate.
- Then insert the mains plug of the mains part into the mains socket.
- After using the blood pressure monitor, unplug the mains part from the mains socket first and then disconnect it from the blood pressure monitor. As soon as you unplug the mains part, the blood pressure monitor loses the date and time setting but the saved measured values are retained.

5. Measuring blood pressure

Please ensure the device is at room temperature before measuring. The measurement can be performed on the left or right arm.

Positioning cuff

Fit the cuff round your bare upper arm. Blood circulation in the arm should not be restricted by tight clothing or other objects.

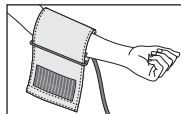

The cuff should be placed on the upper arm so that the lower edge is 2 to 3 cm above the bend of the elbow and above the artery. The tube should be in line with the centre of the palm.

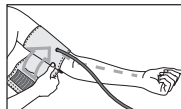

Now place the free end of the cuff snugly, but not too tightly, around the arm, and fix it with the Velcro fastener. The cuff should be fitted tight enough to allow just two fingers to fit beneath the cuff.

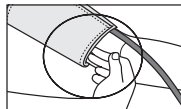

Insert the cuff tubing into the socket for the cuff attachment.

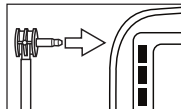

This cuff is suitable for you if the index mark (▼) is within the OK range after fitting the cuff on the upper arm.

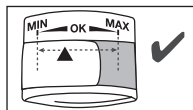

i If the measurement is performed on the right upper arm, the line should be located on the inside of your elbow. Ensure that your arm is not pressing on the line.

Blood pressure may vary between the right and left arm, which may mean that the measured blood pressure values are different. Always perform the measurement on the same arm. If the values between the two arms are significantly different, please consult your doctor to determine which arm should be used for the measurement.

Important: The instrument should only be operated with the original cuff. The cuff is suitable for an arm circumference of 22 to 35 cm.

A larger cuff for upper arm circumferences from 30 to 42 cm is available from retailers or the service address under order no. 162.973.

Adopting the correct posture

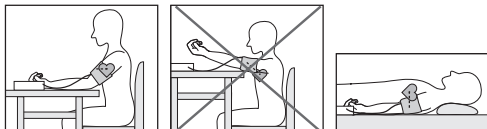

- Rest for approx. 5 minutes before each measurement. Otherwise there may be divergences.
- You can perform the measurement either sitting or lying down. Always make sure that the cuff is on a level with your heart.
- To carry out a blood pressure measurement, make sure you are sitting comfortably with your arms and back leaning on something. Do not cross your legs. Place your feet flat on the ground.
- In order not to distort the result, it is important to keep still during the measurement and not talk.

Performing the blood pressure measurement

Measurement

- As described above, attach the cuff and adopt the posture in which you want to perform the measurement.
- Start the device with the START/STOP button . Following the display check, during which all numbers light up, the cuff inflates automatically.
- The cuff is inflated to 190 mmHg. The cuff's air pressure is slowly released. If you already recognise a tendency for high blood pressure, you should reinflate the cuff and increase the cuff's pressure again. As soon as a pulse is detected, the pulse symbol flashes.

ⓘ Measuring can be cancelled at any time by pressing the START/STOP button .

- Systolic pressure, diastolic pressure and pulse readings are displayed.
- Er_ appears if the measurement has not been performed properly. Observe the chapter on error messages/trouble-shooting in these instructions for use and repeat the measurement.
- The measurement is automatically stored.
- The device switches off automatically after 3 minutes.

Wait at least 5 minutes before taking another measurement!

6. Evaluating results

Cardiac arrhythmia:

This instrument can identify possible cardiac arrhythmia disorders during measurement and if necessary indicates the measurement with the flashing icon .

This may be an indicator for arrhythmia. Arrhythmia is a condition where the heart rhythm is abnormal as a result of defects in the bioelectrical system controlling the heart beat. The symptoms (omitted or premature heart beats, slow or excessively fast heart rate) may be caused, among other things, by heart disease, age, physical predisposition, excessive use of stimulants, stress or lack of sleep. Arrhythmia can only be ascertained through examination by your doctor.

Repeat the measurement if the flashing icon  is displayed after the measurement. Please note that you should rest for

5 minutes between measurements and not talk or move during the measurement. If the icon  appears often, please contact your doctor. Any self-diagnosis and treatment based on the test results may be dangerous. It is vital to follow your doctor's instructions.

Risk indicator:

The measurements can be classified and evaluated in accordance with the following table.

However, these standard values serve only as a general guideline, as the individual blood pressure varies in different people and different age groups etc.

It is important to consult your doctor regularly for advice. Your doctor will tell you your individual values for normal blood pressure as well as the value above which your blood pressure is classified as dangerous.

The bar graph in the display and the scale on the unit indicate the range of the blood pressure which has been recorded.

If the values for systolic and diastolic pressure are in two different ranges (e.g. systolic in the high-normal range and diastolic pressure in the normal range) the graphic classification on the unit indicates the higher range (high-normal in the example described).

Blood pressure value category	Systole (in mmHg)	Diastole (in mmHg)	Action
Setting 3: severe hypertension	≥ 180	≥ 110	seek medical attention
Setting 2: moderate hypertension	160–179	100–109	seek medical attention
Setting 1: mild hypertension	140–159	90–99	regular monitoring by doctor
High normal	130–139	85–89	regular monitoring by doctor
Normal	120–129	80–84	self-monitoring
Optimal	< 120	< 80	self-monitoring

Source: WHO, 1999 (World Health Organization)

7. Saving, displaying and deleting measured values

User memory

The results of every successful measurement are stored together with the date and time. If there are more than 60 measurements, the oldest measurements are lost.

- Select the desired user memory (M1 M2) by pressing the **SET** button and the function buttons **-/+**. Confirm your selection with the START/STOP button .

Average values

- Press the memory button **M**. The average value of all saved measured values in this user memory is displayed first **RL**.
 - If you press the memory button **M** again, the average value of the morning measurements for the last 7 days will be displayed (morning: 5.00 a.m. – 8.59 a.m., display **R**).
 - If you press the memory button **M** again, the average value of the evening measurements for the last 7 days will be displayed (evening: 6.00 p.m. – 7.59 p.m., display **P**).
-  If there is no measurement in the memory, the device displays - - -.

Individual measured

- If you press the function buttons **-/+**, the most recent individual measured values are displayed in turn with the date and time. By pressing the function button **+** the most recent measurements are displayed; by pressing the function button **-**, the oldest are displayed.

- To clear the memory of the relevant user memory, you must first select a user memory. Start a request for either average values or individual measured values and press and hold the **SET** button for approx. 3 seconds. All the values in the current user memory are deleted after 3 brief beeps are output.
- You have the option to delete individual measured values by pressing the **SET** button when the measured values are displayed after the measurement.
- To switch off, press the START/STOP button .
- If you forget to switch off the device, it will switch off automatically after 3 minutes.

8. Cleaning and storing the device and cuff

- Clean the device and cuff carefully using a slightly damp cloth only.
- Do not use any cleaning agents or solvents.
- Under no circumstances hold the device and cuff under water, as this can cause liquid to enter and damage the device and cuff.
- If you store the device and cuff, do not place heavy objects on the device and cuff. Remove the batteries. The cuff line should not be bent sharply.

9. Error messages/troubleshooting

In case of faults, the E_r__ message appears in the display. Error messages can occur when

- E_r-1: Systolic pressure is not detected,
- E_r-2: Diastolic pressure is not detected,

- E_r-3: The cuff is fastened too tightly or loosely,
- E_r-4: The pump pressure is higher than 300 mmHg,
- E_r-5: There is a system or unit error.

In the above cases, you must repeat the measurement. Make sure that the cuff tube is properly inserted and that you do not move or talk. Re-insert the batteries if necessary, or else replace them.

10. Specifications

Model no.	BM 40
Measurement method	Oscillometric, non-invasive blood pressure measurement on the upper arm
Measurement range	Cuff pressure 0–300 mmHg, systolic 60–280 mmHg, diastolic 30–200 mmHg, Pulse 30–180 beats/minute
Display accuracy	Systolic ± 3 mmHg, diastolic ± 3 mmHg, pulse ± 5 % of the value shown
Measurement inaccuracy	Max. permissible standard deviation according to clinical testing: systolic 8 mmHg/diastolic 8 mmHg
Memory	2 x 60 memory spaces
Dimensions	L 119 mm x W 109 mm x H 60 mm
Weight	Approx. 257 g (without batteries)
Cuff size	22 to 35 cm
Permissible operating conditions	+10 °C to +40 °C, 15-93 % relative air humidity (non-condensing)

Permissible storage conditions	-25 °C to +55 °C, ≤ 93 % relative air humidity, 700–1060 hPa ambient pressure
Power supply	4 x 1,5V  AA batteries
Battery life	For approx. 250 measurements, depending on the blood pressure level and/or pump pressure
Classification	Internal supply, continuous operation, type BF applied part, IP22, no AP or APG

The serial number is located on the device or in the battery compartment.



Technical information is subject to change without notification to allow for updates.

- This unit is in line with European Standard EN 60601-1-2 (In accordance with CISPR 11, IEC61000-3-2, IEC61000-3-3, IEC61000-4-2, IEC61000-4-3, IEC61000-4-4, IEC61000-4-5, IEC61000-4-6, IEC61000-4-8, IEC61000-4-11) and is subject to particular precautions with regard to electromagnetic compatibility (EMC). Please note that portable and mobile HF communication systems may interfere with this unit.
- This device is in line with the EU Medical Devices Directive 93/42/EEC, the „Medizinproduktegesetz“ (German Medical Devices Act) and the standards EN 1060-1 (non-invasive sphygmomanometers, Part 1: General requirements), EN 1060-3 (non-invasive sphygmomanometers, Part 3: Supplementary requirements for electro-mechanical blood pressure measuring systems) and IEC 80601-2-30 (Medical electrical equipment – Part 2–30: Particular requirements for the

safety and essential performance of automated non-invasive blood pressure monitors).

- The accuracy of this blood pressure monitor has been carefully checked and developed with regard to a long useful life. If using the device for commercial medical purposes, it must be regularly tested for accuracy by appropriate means. Precise instructions for checking accuracy may be requested from the service address.

11. Mains part

Model no.	LXCP12-006060BEH
Input	100–240V, 50–60 Hz, 0.5A max
Output	6V DC, 600mA, only in connection with beurer blood pressure monitor.
Supplier	Shenzhen longxc power supply co., ltd
Protection	This device is double insulated and protected against short circuit and overload by a primary thermal fuse. Make sure to take the batteries out of the compartment before using the mains part.
	Polarity of the the DC voltage connection
	Double insulated/equipment class 2

Enclosures and Protective Covers	Equipment enclosed to protect against contact with live parts, and with parts which can become live (finger, pin, hook test). The operator shall not contact the patient and the output plug of AC mains part simultaneously.
----------------------------------	--

12. Replacement parts and wearing parts

Replacement parts and wearing parts are available from the corresponding listed service address under the stated material number.

Designation	Item number and/or order number
Standard cuff (22-35 cm)	162.972
XL cuff (30-42 cm)	162.973
Mains part (EU)	071.95
Mains part (UK)	072.05

13. Warranty/service

In case of a claim under the warranty please contact your local dealer or the local representation which is mentioned in the list “service international”.

In case of returning the unit please add a copy of your receipt and a short report of the defect.

The following warranty terms shall apply:

- The warranty period for BEURER products is either 5 years or- if longer- the country specific warranty period from date of Purchase.
In case of a warranty claim, the date of purchase has to be proven by means of the sales receipt or invoice.
- Repairs (complete unit or parts of the unit) do not extend the warranty period.
- The warranty shall not be valid for damages because of
 - improper treatment, e.g. nonobservance of the user instructions.
 - repairs or tampering by the customer or unauthorised third parties.
 - transport from the manufacturer to the consumer or during transport to the service centre.
 - The warranty shall not be valid for accessories which are subject to normal wear and tear (cuff, batteries etc.).
- Liability for direct or indirect consequential losses caused by the unit are excluded even if the damage to the unit is accepted as a warranty claim.